

1. Details of Module and its structure

Module Detail	
Subject Name	Physics
Course Name	Physics 04 (Physics Part 2, Class XII)
Module Name/Title	Unit-09, Module-05: Experiments with semiconductor diodes Chapter-14: Semiconductor Electronics: Materials, Devices and Simple Circuits
Module Id	leph_201405_eContent
Pre-requisites	Semiconductors, intrinsic semiconductors, extrinsic semiconductors, p-n junction diode, forward and reverse bias, IV characteristics, working and uses of optoelectronic junction device, solar cell, photodiode, LED
Objectives	After going through this module learner will be able to: <ul style="list-style-type: none"> • Identify and distinguish a diode, an LED, a resistor and a capacitor • Understand the application of a multimeter to <ol style="list-style-type: none"> i) See the unidirectional flow of current in case of a diode and an LED ii) Check whether a given diode is in working order
Keywords	LED, junction diode, checking a diode, multimeter to check LED, multimeter to check resistance,

2. Development Team

Role	Name	Affiliation
National MOOC Coordinator (NMC)	Prof. Amarendra P. Behera	Central Institute of Educational Technology, NCERT, New Delhi
Programme Coordinator	Dr. Mohd Mamur Ali	Central Institute of Educational Technology, NCERT, New Delhi
Course Coordinator / (PI)	Anuradha Mathur	Central Institute of Educational Technology, NCERT, New Delhi
Subject Matter Expert (SME)	Chitra Goel	PGT Physics, Retd Principal Pratibha Vikas Vidhyalaya
Review Team	Prof. V. B. Bhatia (Retd.) Associate Prof. N.K. Sehgal (Retd.) Prof. B.K. Sharma (Retd.)	Delhi University Delhi University DESM, NCERT, New Delhi

TABLE OF CONTENT

1. Unit syllabus
2. Module wise distribution of unit syllabus
3. Words you must know
4. Introduction
5. Multimeter
6. To identify a Diode, a LED, a Resistor and a Capacitor from a mixed collection of such items
7. To plot volt-ampere characteristics of silicon p-n junction diode
8. Summary

1. UNIT SYLLABUS

Unit-09: Electronic Devices

Chapter-14: semiconductor electronic material, devices and simple circuits.

Energy bands in conductors, semiconductors and insulators (qualitative only)

Semiconductors intrinsic and extrinsic

Semiconductor diode: I-V characteristics in forward and reverse bias, application of diode as a rectifier

Special purpose p-n diodes: LED, photodiode, solar cell and Zener diode and their characteristics, Zener diode as a voltage regulator

Junction transistor, transistor action, characteristics of a transistor and transistor as amplifier common emitter configuration

Basic idea of analog and digital signal, logic gates OR, AND, NOR, NOT, NAND

Keeping the needs of state boards in mind we have not changed the content

2. MODULE WISE DISTRIBUTION OF SYLLABUS

10 MODULES

Module 1	<ul style="list-style-type: none"> • Energy bands in solids • Forbidden gap • Fermi level • Energy bands in conductors , semiconductors and insulators
Module 2	<ul style="list-style-type: none"> • Uniqueness of semiconductors • Charge carriers in semiconductors electrons and holes • Intrinsic semiconductors

	<ul style="list-style-type: none"> • Extrinsic semiconductors p and n type • Why are p and n type semiconductors neutral?
Module 3	<ul style="list-style-type: none"> • p-n junction diode • Potential barrier • Depletion layer • Characteristics of p-n junction diode • forward and reverse bias, knee voltage • junction in forward bias and reverse bias • magnitude of bias voltages
Module 4	<ul style="list-style-type: none"> • Application of diode • Rectifier meaning and need of such a device • half wave and full wave rectifier • rectifier in our homes • Special purpose diode LED Photodiode Solar cells • Solar panels and future of energy
Module 5	<ul style="list-style-type: none"> • To identify a diode, an LED, a resistor and a capacitor • use a multimeter to <ul style="list-style-type: none"> i) see the unidirectional flow of current in case of a diode and an LED ii) check whether a given diode is in working order • Characteristic curves of p-n junction diode
Module 6	<ul style="list-style-type: none"> • Zener diode • Characteristics of Zener diode • To draw the characteristic curve of a Zener diode and to determine its reverse breakdown voltage • How is Zener diode different from other diodes? • Zener diode as a voltage regulator • Working of a Zener diode • Zener diodes in our homes
Module 7	<ul style="list-style-type: none"> • Junction transistor • design of the transistor • n-p-n and p-n-p • use a multimeter to <ul style="list-style-type: none"> i) identify base of transistor ii) distinguish between n-p-n and p-n-p type

	<p><i>transistor</i></p> <p>iii) <i>see the unidirectional flow of current in case of a diode and an LED</i></p> <ul style="list-style-type: none"> • iv) check whether a given electronic component (e.g. diode , transistor, or IC) is in working order • transistor action • characteristics of a transistor • n-p-n -common emitter
Module 8	<ul style="list-style-type: none"> • Understanding transistor characteristics and its applications • To study the characteristic of a common emitter n-p-n and p-n-p transistor and to find the values of current and voltage gains. • Transistor as switch • Transitory as amplifier
Module 9	<ul style="list-style-type: none"> • Transistor as an amplifier • Circuit diagram and understanding bias • Input and output waveforms • Phase change
Module 10	<ul style="list-style-type: none"> • Analog signals • Logic gates • Truth tables • OR gate • AND gate • NOT gate • NAND gate • NOR gate

MODULE 5

3. WORDS YOU MUST KNOW

Conductors: These are the materials which conduct electricity easily. They have very large number of free electrons.

Insulators: These are the materials which do not conduct electricity because they do not have free electrons.

Semiconductors: These are the materials for which electrical conductivity value is less than conductors but more than insulators. The conductivities of semiconductors are highly temperature sensitive.

Energy level: As per Bohr's theory electrons revolve around the nucleus only in some specific orbits called stationary orbits. Energy of electrons in these orbits is constant. These orbits are termed as energy levels.

Valence bands: This band comprises of energy of valence electrons. Electrons of this band do not contribute in conduction of electric current.

Conduction band: This band corresponds to energy of free electrons. Electrons of this band are responsible for conduction of electric current.

Forbidden energy gap (E_g): It is the minimum energy required to take an electron from valence band to conduction band. Insulators have highest E_g and conductors have least E_g .

Intrinsic semiconductors: These are pure semiconductors without any impurity. they show very small electrical conductivity at room temperature.

Doping: It is the deliberate and controlled addition of impurities in intrinsic semiconductors to enhance their electrical conductivity in a controlled manner.

Extrinsic semiconductors: Semiconductors to which impurities are added to increase conductivity are known as extrinsic semiconductors or impurity semiconductors

Dopant: Two types of dopants used in doping of the Si or Ge element:

- (i) *Pentavalent dopants (valency 5); like Arsenic (As), Antimony (Sb), Phosphorous (P), etc.*
- (ii) *Trivalent dopants (valency 3); like Indium (In), Boron (B), Aluminium (Al), etc.*

p-type semiconductors: These are formed by doping elements like Si and Ge with trivalent atoms.

n-type semiconductors: These are formed by doping elements like Si and Ge with pentavalent atoms.

p-n JUNCTION: A p-n junction is a boundary, or interface between the two types of semiconductors, (p-type and n-type), inside a single crystal.

Diffusion current: Holes diffuse from p-side to n-side ($p \rightarrow n$) and electrons diffuse from n-side to p-side ($n \rightarrow p$).

Potential barrier: Initially both the sides were electrically neutral. Now, because of diffusion of electrons and the holes, there are immobilised additional ions on both the sides.

From the n side, electrons have diffused to p side, so there are positive immobile ions on the n side, from the p side, holes have diffused to the n side, so there are negative immobile ions on the p side. These immobile ions near the junction creates a potential difference across the junction.

Drift current: Due to the positive space-charge region on n-side of the junction, and negative space charge region on p-side of the junction, an electric field, directed from positive charge towards negative charge develops.

- Due to this field, an electron on p-side of the junction moves to n-side and a hole on n-side of the junction moves to p-side.
- The motion of charge carriers due to the electric field is called drift.

a drift current, which is opposite in direction to the diffusion current is set up.

Forward bias: When an external voltage V is applied across a semiconductor diode such that p-side is connected to the positive terminal of the battery and n-side to the negative terminal it is said to be forward biased.

Reverse Bias: The positive terminal of the battery is connected to the n-side of the semiconductor and negative terminal is connected to the p-side. This way of connecting a diode with a battery is called Reverse Biasing.

Characteristics of a p-n junction diode

When a bias is placed across a conductor, its characteristic curves shows the dependence of current on voltage placed across the conductor.

Knee voltage: The special value of forward bias voltage beyond which the current increases with increase in the voltage is known as the knee Voltage.

Dynamic resistance of a junction diode

The **I-V** characteristics of a p-n junction diode during forward /reverse biasing is not a straight line. We therefore cannot have a have a unique (constant) value for the resistance of the diode. We can, however use the basic definition of resistance

$$\text{resistance} = \frac{\text{change in potential difference}}{\text{corresponding change in current}}$$

We can use it to define

Dynamic resistance of a junction diode (for a particular value of the applied current flowing) is defined as the ratio of small change in the applied potential across the diode to the corresponding small change in the junction current.

$$\text{dynamic resistance} = \frac{\Delta V}{\Delta I}$$

Rectifier is a device which converts an alternating current (AC) into a direct current (DC).

Filter circuit: The ripples in the DC can be reduced by allowing the output to pass through a **filter circuit**.

Photodiodes used for detecting optical signals (photodetectors).

Light emitting diodes (LED) which convert electrical energy into light.

Photovoltaic devices which convert optical radiation into electricity (**solar cells**)

4. INTRODUCTION

Semiconductor devices are used in practically every electronic device today. understanding methods which are used in order to recognise them and set them in simple circuits is very important.

The very idea of studying basic concepts of semiconductor material behaviour under different conditions helps us to use them more and more. This has improved performances of every day appliances.

Example is the electric bulb in our home, earlier was a bulb based on heating effect of a high resistance conductor (tungsten), which was replaced by CFLs and now by LED.

As the semiconductor devices operate on low voltages thus their use **saves energy**. **Solar panels are the new electrical energy generation devices.**

In this module we will learn some common methods used for study of semiconductor devices which are commonly placed in useful circuits.

each other) the scale of this setting of the multimeter, goes from right to left. The markings are such that, the zero is on the extreme right and infinity on extreme left. Further the scale is non-linear. As the deflection of the pointer is proportional to $1/R$

- The multimeter measures the electrical current that flows and uses this to show the resistance of the object in “ohms” units

First, check a **metal object**:



the resistance should be very close to zero ohms because metals are very good conductors of electricity.

Next, **plastic or wooden block**:



the resistance should be extremely high, because these are all very bad conductors of electricity (insulators).

Now try **the pencil with graphite**:



touch the multimeter probes to the lead on each end of the pencil. You should get a **reading of somewhere around 10 ohms to 100 ohms**. This means that the pencil lead (graphite) can conduct electricity, but it is not as good as most metals conductors.

You can also, try this yourself:

Hold one of the probe in each hand, and see what your resistance is (don't worry; the battery in the multimeter is not strong enough to give you a shock). If your hands are dry, you will probably have nearly infinite resistance. If your hands are sweaty, or if you wet your fingertips before taking hold of the probe, you should have a resistance somewhere around 50,000 ohms.



This means that while your body has a lot of resistance, it has less resistance than an insulator like a piece of wood.

That is why one can get electrical shock (because electricity can flow through our body), and why using electrical appliances near water is not desirable (because if one is wet, one has a lot less electrical resistance than if one is dry).

The three physical quantities that the multimeter can measure are **resistance, current and potential difference**, hence the name multimeter. Choice of scale, to measure the relevant quantity in any particular case can be done using the knobs provided.

6. TO IDENTIFY A DIODE, A LED, A RESISTOR and A CAPACITOR FROM A MIXED COLLECTION OF SUCH ITEMS



We can use a multimeter to

- i) Identify different two terminal components from a collection.
- ii) See the unidirectional flow of current in a diode or LED
- iii) Check whether a given diode is in working order.

The above application of the multimeter is based on the fact that diodes and LED offers a very low resistance when forward biased and a large resistance when reverse biased.

Principle

A diode, resistance, capacitor, LED are all two terminal device

S no	Device	Salient features
1	Resistance	A two-terminal device which conducts equally in both directions
2	Capacitor	A two terminal device. It does not conduct but stores some charge when dc voltage is applied
3	Diode	A two terminal device. It conducts when forward biased and does not conduct when reverse biased, it does not emit light while conducting
4	LED	A two terminal device. it conducts when forward biased and does not conduct when reverse biased. it emits light while conducting

We set the multimeter knob in the **position in which we measure resistance**. Select a suitable range; may be in kilo ohm using the selector knob of the multimeter.

Usually there are black and red wires, with plug type insertable probes. It is a good idea to plug the red to the positive terminal and black to the negative terminal on the

multimeter. This ensures that we know the polarity of the probe ends when we touch the devices which we are testing. This is only for convenience.

When the metal probe ends of the multimeter leads are in contact the multimeter should show zero resistance.

If it does not show it, bring the pointer to zero using the zero adjust knob

As seen and checked our bodies offer resistance which depends upon the moisture around our hands and so we should not hold the device in our hands. Instead keep them on a wooden surface and use the probes to touch the terminals of the device.

Put the devices between the probes, one at a time and complete the table given.

For example, if the device shows same value even when the probes are interchanged, means the device offers same resistance, whichever end way it is connected, hence it can only be a **pure resistance.**

The responses and inferences are given. Study these carefully they should help you to do it yourself

CHECKING FOR THE STATE OF CONDUCTION

S no	State of conduction	Device code	Name of the device
1	Conducts in one direction only without emission of light		
2	Conducts in one direction only with emission of light		
3	Conducts in both directions		
4	Does not conduct, gives an initial deflection which decays to zero		

EXAMPLE

Two devices X and Y are given to you. Both show current flow in the circuit only in one direction. Y emits light. Identify the LED.

SOLUTION: Y

EXAMPLE

Diode X has two terminals and has a silver circular strip marked closer to one of the terminals on it. Choose the appropriate method to determine the p and the n side of the diode.

**SOLUTION**

- I)** Connect the multimeter probes to the two terminals observe the resistance offered by the diode.
Interchange the terminals, observe the resistance again
- II)** Connect the multimeter probes to the two terminals,
Make note of the terminal closer to the silver strip,
Observe the resistance offered by the diode.
Interchange the terminals observe the resistance again
- III)** Connect the multimeter probes to the two terminals, make note of the terminal closer to the silver strip,
Observe the resistance offered by the diode.
Make a note of the resistance value
Interchange the terminals observe the resistance again noting it

EXAMPLE

Use the colour code to mark the coloured rings on a carbon resistance if, the multimeter shows a deflection of

- a) 4200 ohms,
b) 500 ohms
c) 4 ohms

0	Black
1	Brown
2	Red
3	Orange
4	Yellow
5	Green
6	Blue
7	Purple
8	Grey
9	White
$\pm 5\%$	Gold
$\pm 10\%$	Silver
Colour Codes	

<http://apps.usd.edu/coglab/psyc770/resistors/colcodes.gif>

SOLUTION

- a) yellow red red
- b) green black brown
- c) black yellow black

we cannot judge its tolerance with just the multimeter.

TO CHECK WHETHER A DIODE IS IN PROPER WORKING CONDITION

- The diode or an LED would let a noticeable current to flow in the circuit only when it is forward biased. It, therefore, permits only a unidirectional flow of current in the circuit in which it is connected.
- A given diode / LED is in proper working order if it is showing a low resistance value in its forward biased and a high resistance when reverse biased.
- If the given diode shows low or high resistance for BOTH types of connections of the multimeter, it is NOT in proper working order.

7. TO PLOT VOLT-AMPERE CHARACTERISTICS OF SILICON p-n JUNCTION DIODE.

TO FIND CUT-IN VOLTAGE FOR SILICON p-n JUNCTION DIODE.

TO FIND STATIC AND DYNAMIC RESISTANCES IN BOTH FORWARD AND REVERSE BIASED CONDITIONS FOR p-n JUNCTION DIODE.

Apparatus Required:

- i) p-n Junction Diode IN4001

(Commercial diode number indicates the manufacturing details and is indicative of the characteristics of the diode. This in turn makes its application in a desired way. The number depends upon the material of the diode, (Ge or Si) and the doping level)

- ii) **Resistance 1k ohm**
- iii) **Regulated power supply (0 – 30V)**
- iv) **Two ammeters of range a) (0-30) mA, b) (0-500) μ A**
- v) **Voltmeter mV (0 – 1)V, (0 – 30)V**
- vi) **connecting wires**

RECALL THESE

p-n junction- A trivalent impurity suitably added to a n-type wafer of silicon helps to make a p-n junction

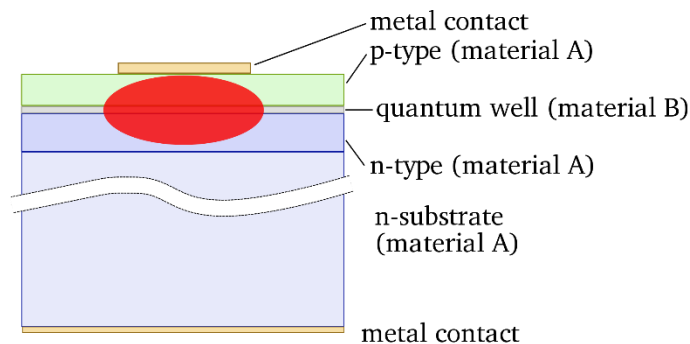

https://upload.wikimedia.org/wikipedia/commons/thumb/4/42/Simple_qw_laser_diode.svg/2000px-Simple_qw_laser_diode.svg.png

Diode symbols

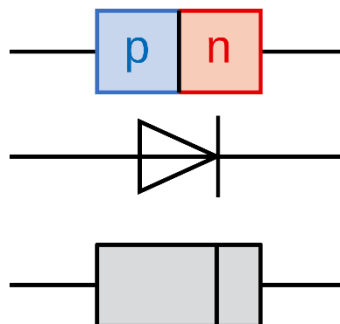

Forward bias –When an external voltage is applied to a p-n junction diode in such a way that the p-side is at a higher potential or (is biased to have higher potential) as compared to the n-type.

Threshold voltage or cut-off voltage or knee voltage

When the p side is connected to the positive terminal of the battery and the voltage is increased gradually, initially a negligible current flows till the applied voltage crosses a certain value. After this characteristic voltage, the diode current increases significantly (exponentially) even for a very small increase in the diode bias voltage. **This voltage is called Threshold voltage or cut-off voltage or knee voltage.**

Reverse bias

When the n region of a p-n junction diode is at a higher potential as compared to the p-region, it is said to be reverse biased. In reverse bias the p side of the p-n junction is connected to the negative of the battery

Reverse saturation current

As the applied voltage is increased in reverse biased condition, starting from zero voltage, the current increases, but soon becomes constant. This small and nearly constant current (a few microamperes) is called the reverse saturation current

THINK ABOUT THESE

- i) *What factors will govern the amount of doping?*
- ii) *How is the depletion region a formed in the p-n junction?*
- iii) *What is leakage current?*
- iv) *What is the effect of temperature on the reverse bias characteristics of a diode?*
- v) *What is cut-in or knee voltage? Why is its value different in the case of Ge or Si?*
- vi) *What is the difference between Ge and Si diode?*
- vii) *What is the relationship between depletion width and the concentration of impurities?*

PROCEDURE

The circuit arrangement for studying the V-I characteristics of a diode, (i.e., the variation of current as a function of applied voltage) is shown in circuit diagram

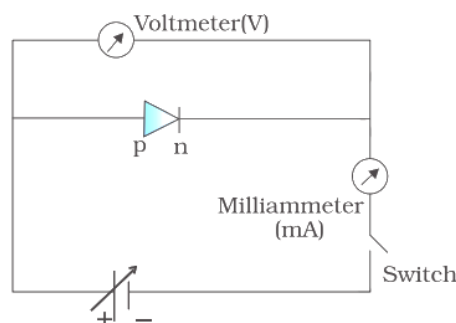

Circuit Diagram for forward Bias characteristic curves

The battery is connected to the diode through a potentiometer (or rheostat) so that the voltage applied to the diode can be changed. For different values of voltages, the value of the current is noted.

A graph between V and I is plotted.

Note that in forward bias measurement, we use a milliammeter since the expected current is large (as explained in the earlier) while a micro-ammeter is used in reverse bias (Figure (b)) to measure the relatively smaller current

$$1 \text{ milli ampere} = 10^{-3} \text{ A}$$

$$1 \text{ micro ampere} = 10^{-6} \text{ A}$$

- Set up the circuit as shown.
- Check the p and n-side of the diode
- Take care of the p and n-side of the diode.
- Make sure that the diode is in working condition
- Make note of the diode specifications
- Study the least count of the voltmeter and the milli / micro ammeter

Keep answering the following questions

- Why are we using a variable bias?
- Why should we choose the ammeter of range 0-10 mA
- Why is it advisable to use a high resistance in the range of 1000 ohms connected in series, in the circuit?

The voltage across the diode should be restricted to keep the current through it small. Allowed maximum current should be known from the manufacturing data linked to its number.

- Why should the forward bias voltage be increased gradually? In steps of 0.1V?

Make an observation table

Range of voltmeter = 0- ...V

Least count of voltmeter scale = ...V

Range of milliammeter = 0- ...mA

Least count the milli ammeter scale =mA

Note readings of current at different values of voltage

S no.	Forward voltage (V volts)	Forward current (I mA)
1		
2		
3		
4		

Take at least five readings after the current is recorded in forward bias

Plot a graph between forward voltage (v) along the positive x axis and current flowing through the diode (I) along the positive y axis.

THINK

- How will you determine the knee voltage?
- What external factors temperature, connecting wires, pressure will influence the value of knee voltage?
- What internal factors material, doping will influence the value of knee voltage?

Graph and Inferences

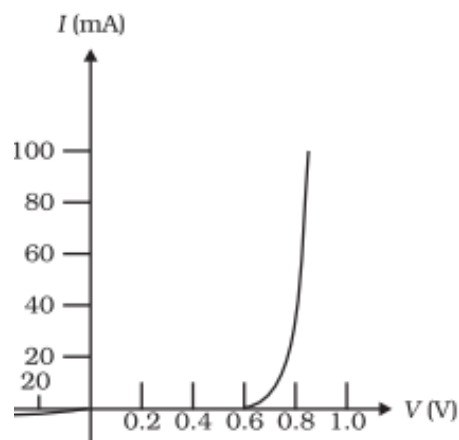

- The value of current flowing through the diode is negligible till the voltage across the diode exceeds the value of its threshold voltage (**which part of the graph is showing this**)
- After the threshold voltage the current increases rapidly (**which part of the graph is showing this**)
- Would it be possible to confirm this behaviour of a semiconductor diode without doing this experiment?

EXAMPLE

Explain the forward bias graph for a p-n junction diode at different temperatures.

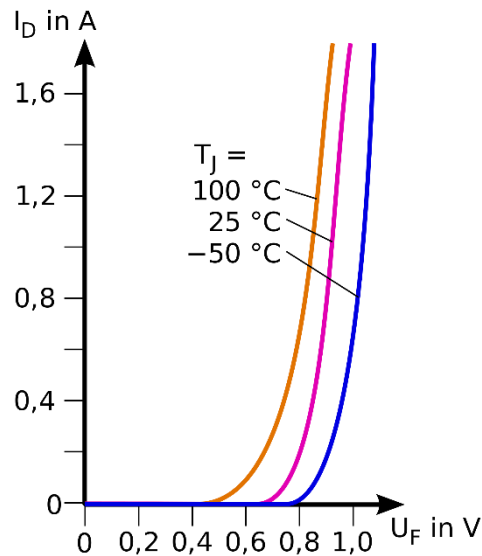

https://upload.wikimedia.org/wikipedia/commons/thumb/1/10/Dioden-Kennlinie_1N4001.svg/2000px-Dioden-Kennlinie_1N4001.svg.png

SOLUTION

The electron hole activity increases with rise in temperature, the potential across the depletion layer decreases.

REPEAT THE STUDY USING REVERSE BIAS

Circuit for reverse bias

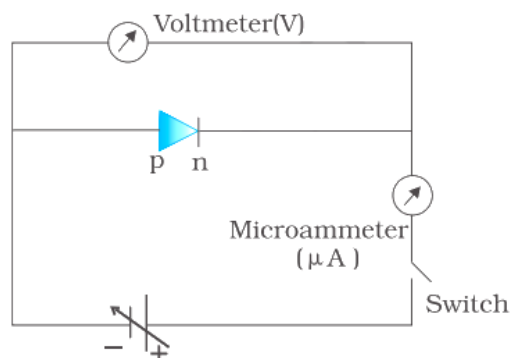

Circuit Diagram for reverse bias characteristic curves

Plot a reverse voltage (v) along the negative x axis. **Why should we do this?**

Corresponding current (in μA) along the negative y-axis. **Why should we do this ?**

Graph and Inference

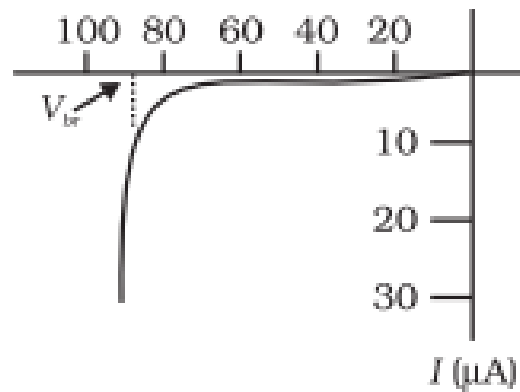

- Determine the reverse saturation current
- Compare the two graphs
- Use the graph and calculate the dynamic resistance

EXAMPLE

Justify the characteristic curve for forward and reverse bias on the same graph.

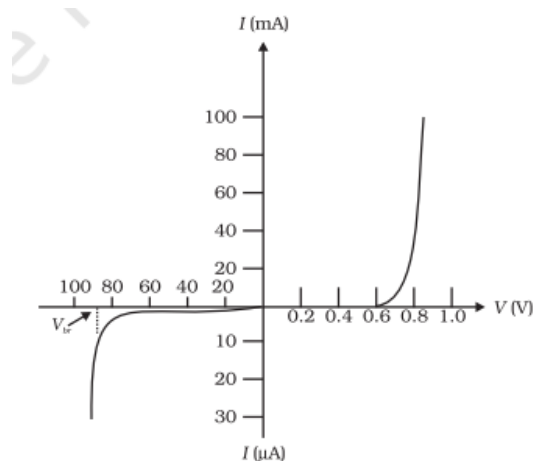

SOLUTION

The negative x axis represents reverse bias the scale used on it is different from the + x axis

EXAMPLE

The threshold voltage or cut-in voltage is $\sim 0.2V$ for germanium diode and $\sim 0.7V$ for silicon diode. Justify that the p-n junction diode is made of germanium

SOLUTION

The current, in forward bias starts flowing only when the applied voltage around $0.6V$

EXAMPLE

What is the difference between a resistance and a diode, both diode and resistance have two terminals?

SOLUTION

a) We can distinguish between them using a multimeter

The diode has different resistances in the two directions, as one would make it forward bias and the other reverse bias, but the resistance of a resistor remains the same.

b) The V-I characteristics for a resistor will be a straight line for resistance following Ohm's law, the forward bias V-I graph for the diode is as shown.

REMEMBER THE PRECAUTIONS WE NEED TO TAKE

- While doing the experiment do not exceed the ratings of the diode. This may lead to damage of the diode.
- Connect voltmeter and Ammeter in correct polarities as shown in the circuit diagram.
- Do not switch ON the power supply unless you have checked the circuit connections as per the circuit diagram.

8. SUMMARY

You have learnt in this module

- The salient features of two terminal devices that we use in the laboratory.

S no	Device	Salient features
1	Resistance	A two-terminal device which conducts equally in both directions
2	Capacitor	A two terminal device. It does not conduct but stores some charge when dc voltage is applied
3	Diode	A two terminal device. It conducts when forward biased and does not conduct when reverse biased it does not emit light while conducting
4	LED	A two terminal device. It conducts when forward biased and does not conduct when reverse biased. It emits light while conducting

- Using a multimeter to distinguish between a set of resistances, diodes and capacitors

- Set up a circuit to study the characteristics of a diode in forward and reverse bias
- Compare the graphs and deduce the values of dynamic resistance, reverse saturation current